

# Owner's Manual

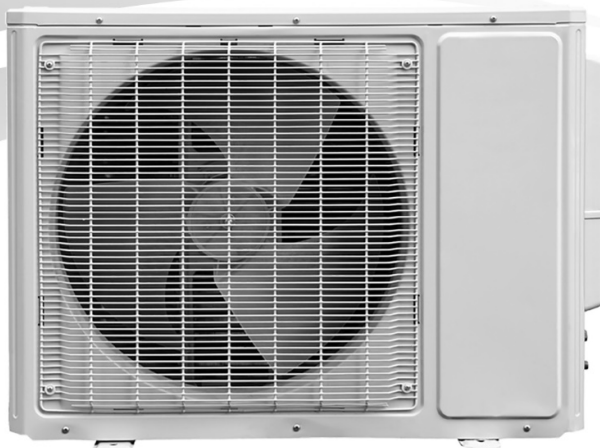

## SPLIT APPLIANCE

22-21 SEER  
18 000 to 42 000 BTU/hr

Models :  
GWHD(18)ND3MO  
GWHD(24)ND3MO  
GWHD(30)ND3MO  
GWHD(36)ND3MO  
GWHD(42)ND3MO



*Please read this owner's manual carefully  
before operating the unit and keep it for future reference.*

The aesthetic and dimensional characteristics, technical data and accessories of this appliance may be changed without notice.

**CONTENTS** **GENERAL INFORMATION**

GENERAL INFORMATION	Conformity And Range	1
	Warning	2
	The Instructions Before Use	5
	Name of Parts	6
	Outdoor Unit Working Temperature Range	6
INSTALLER	Electrical Connections	7
	Installing The Outdoor Unit	11
	Bleeding	11
	Maintenance	12
	Installation Dimension Diagram	12
	Check After Installation	13

The products in this manual may be different from the real one, according to different models, some models have the displayer, and some models are without the displayer. For the position and shape of the displayer please refer to the product in your possession.

This appliance is not intended for use by persons (including children) with reduced physical, sensory or mental capabilities, or lack of experience and knowledge, unless they have been given supervision or instruction concerning use of the appliance by a person responsible for their safety.

Children should be supervised to ensure that they do not play with the appliance.

If you need to install, move or maintain the appliance, please contact dealer or local service center first. The appliance must be installed, moved or maintained by appointed unit.

Otherwise, it may cause serious damage or personal injury or death.

When refrigerant leaks or requires discharge during installation, maintenance, or disassembly, it should be handled by certified professionals or otherwise in compliance with local laws and regulations.

**DANGER**

Indicates a hazardous situation that, if not avoided, will result in death or serious injury.

**WARNING**

Indicates a hazardous situation that, if not avoided, could result in death or serious injury.

**CAUTION**

Indicates a hazardous situation that, if not avoided, may result in minor or moderate injury.

**NOTICE**

Indicates important but not hazard-related information, used to indicate risk of property damage.



Indicates a hazard that would be assigned a signal word WARNING or CAUTION.

Manufacturer will bear no responsibilities when personal injury or property loss is caused by the following reasons.

1. Damage the product due to improper use or misuse of the product;
2. Alter, change, maintain or use the product with other equipment without abiding by the instruction manual of manufacturer;
3. After verification, the defect of product is directly caused by corrosive gas;
4. After verification, the defects are due to improper operation during transportation of product;
5. Operate, repair, maintain the unit without abiding by instruction manual or related regulations;
6. After verification, the problem or dispute is caused by the quality specification or performance of parts and components that produced by other manufacturers;
7. The damage is caused by natural calamities, bad using environment or force majeure.



Please read this owner's manual carefully before operating the unit and keep it carefully for consultation.



Only use the appliance as instructed in this booklet. These instructions are not intended to cover every possible condition and situation. As with any electrical household appliance, common sense and caution are therefore always recommended for installation, operation and maintenance.



## Operation and Maintenance

- This appliance can be used by children aged from 8 years and above and persons with reduced physical, sensory or mental capabilities or lack of experience and knowledge if they have been given supervision or instruction concerning use of the appliance in a safe way and understand the hazards involved.
- Children shall not play with the appliance.
- Cleaning and user maintenance shall not be made by children without supervision.
- Do not connect appliance to multi-purpose socket. Otherwise, it may cause fire hazard.
- Disconnect power supply when cleaning appliance. Otherwise, it may cause electric shock.
- If the supply cord is damaged, it must be replaced by the manufacturer, its service agent or similarly qualified persons in order to avoid a hazard.
- Do not wash the appliance with water to avoid electric shock.
- Do not spray water on indoor unit. It may cause electric shock or malfunction.
- After removing the filter, do not touch fins to avoid injury.
- Do not use fire or hair dryer to dry the filter to avoid deformation or fire hazard.
- Maintenance must be performed by qualified professionals. Otherwise, it may cause personal injury or damage.
- Do not repair appliance by yourself. It may cause electric shock or damage. Please contact dealer when you need to repair appliance.
- Do not extend fingers or objects into air inlet or air outlet. It may cause personal injury or damage.
- Do not block air outlet or air inlet. It may cause malfunction.
- Do not spill water on the remote controller, otherwise the remote controller may be broken.
- When below phenomenon occurs, please turn off the appliance and disconnect power immediately, and then contact the dealer or qualified professionals for service.
  - Power cord is overheating or damaged.
  - There's abnormal sound during operation.
  - Circuit break trips off frequently.
  - The appliance gives off burning smell.
  - Indoor unit is leaking.



- If the appliance operates under abnormal conditions, it may cause malfunction, electric shock or fire hazard.
- When turning on or turning off the unit by emergency operation switch, please press this switch with an insulating object other than metal.
- Do not step on top panel of outdoor unit, or put heavy objects. It may cause damage or personal injury.

## Wiring

- Installation must be performed by qualified professionals. Otherwise, it may cause personal injury or damage.
- Must follow the electric safety regulations when installing the unit.
- According to the local safety regulations, use qualified power supply circuit and circuit breaker.
- Do install the circuit breaker. If not, it may cause malfunction.
- An all-pole disconnection switch having a contact separation of at least 1/8" (3mm) in all poles should be connected in fixed wiring.
- Including a circuit breaker with suitable capacity, please note the following table. Air switch should be included magnet buckle and heating buckle function, it can protect the circuit-short and overload.
- The appliance should be properly grounded. Incorrect grounding may cause electric shock.
- Don't use unqualified power cord.
- Make sure the power supply matches with the requirement of the appliance. Unstable power supply or incorrect wiring may result in electric shock, fire hazard or malfunction. Please install proper power supply cables before using the appliance.
- Properly connect the live wire, neutral wire and grounding wire. Be sure to cut off the power supply before proceeding any work related to electricity and safety.
- Do not turn on the power before finishing installation.
- If the supply cord is damaged, it must be replaced by qualified persons in order to avoid a hazard.
- The temperature of refrigerant circuit will be high, please keep the interconnection cable away from the copper tube.
- The appliance shall be installed in accordance with national wiring regulations.
- Installation must be performed in accordance with the requirement of NEC and CEC by authorized personnel only.



- The heat pump is a first class electric appliance. It must be properly grounding with specialized grounding device by a professional. Please make sure it is always grounded effectively, otherwise it may cause electric shock.
- The yellow-green wire in appliance is grounding wire, which can't be used for other purposes.
- The grounding resistance should comply with national electric safety regulations.
- The appliance must be positioned so that the plug is accessible.
- All wires of indoor unit and outdoor unit should be connected by a professional.
- If the length of power connection wire is insufficient, please contact the supplier for a new one. Avoid extending the wire by yourself.
- For the appliance with plug, the plug should be reachable after finishing installation.
- For the appliance without plug, a circuit breaker must be installed in the line.
- If you need to relocate the appliance to another place, only a qualified person can perform the work. Otherwise, it may cause personal injury or damage.
- Select a location which is out of reach for children and far away from animals or Plants. If it is unavoidable, please add the fence for safety purpose.
- The indoor unit should be installed close to the wall.

WARNING

★ When having a burning smell or smoke, please turn off the power supply and contact with the service center.



If the abnormality still exists, the unit may be damaged, and may cause electric shock or fire.

★ The power supply must adopt the special circuit that with air switch protection and assure it has enough capacity. The unit will be turned on or off automatically according to your requirement, please do not turn on or turn off the unit frequently, otherwise damage may be caused to the unit.

★ Never cut off or damage power cables and control wires. If the power cable and signal control wire were damaged, changes must be made by professional.



★ Power must adopt the special circuit to prevent fire.

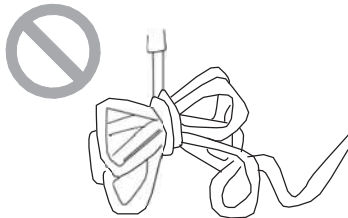

Otherwise, it can cause electric shock or fire.

★ Disconnect the power supply if you are putting the appliance out of use for a long period.



Otherwise, the accumulated dusts may cause overheating or fire.

★ Never damage the electric wire or use the electric wire which is not appointed.



Otherwise, it will cause overheating or fire.

★ When cleaning, it is necessary to turn off the power supply.

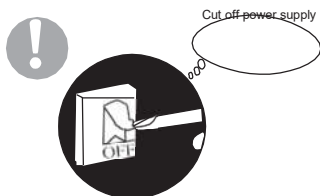

Otherwise, it may cause electric shock or damage.

★ Rated voltage of this appliance is 220-240V, 60Hz, The compressor will vibrate sharply if the voltage is too low. It may cause damage to the refrigerating system. Electrical component are easy to damage if the voltage is too high.

★ Don't attempt to repair the appliance by yourself.

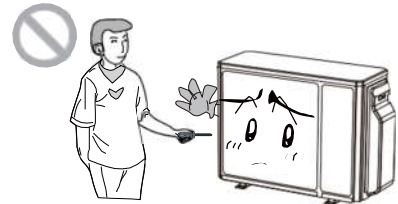

The wrong repair will lead to an electric shock or fire, so you should contact the service center to repair.

★ Please note whether the installed stand is firm enough or not.

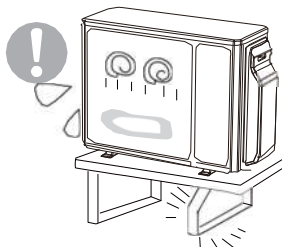

If it is damaged, it may lead to the fall of the unit and cause the injury.

★ Don't step on the top of the outdoor unit or place something on it.

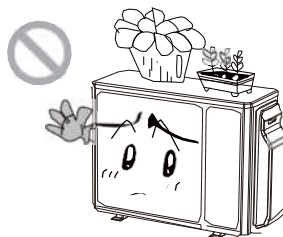

They may fall off the outdoor unit and be dangerous.

★ Grounding: The unit must be reliably grounded. The ground cable shall be connected to the special grounding device in the construction.



**WARNING**

- Be sure to cut off the power supply before cleaning the appliance; otherwise, electric shock might happen.
- Wetting of appliance may cause the risk of electric shock. Make sure not to wash your appliance in any case.
- Volatile liquids such as thinner or gasoline will cause damage to the appearance of the appliance. (Only use soft dry cloth moist cloth clean the appliance cabinet).
- This product must not be disposed together with the domestic waste.  
This product has to be disposed at an authorized place for recycling of electrical and electronic appliances.
- The temperature of refrigerant circuit will be high, please keep the interconnection cable away from the copper tube.

OUTDOOR UNIT	
No.	Description
1	Air outlet grille
2	Valve

Note: The above figures are only intended to a simple diagram of the appliance and may not correspond to the appearance of the units that have been purchased.

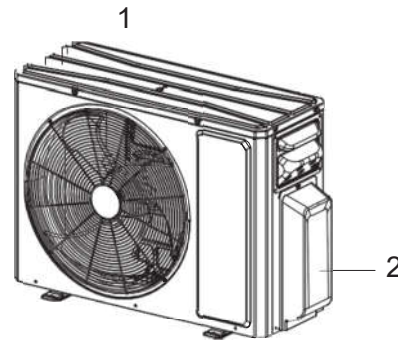

	Indoor side DB/WB(°C/°F)	Outdoor side DB/WB(°C/°F)
Maximum cooling	26.7/19.4(80/67)	43/24(109/75)
Maximum heating	26.7/- (80/-)	23.9/18.3(75/65)

- The operating temperature range (outdoor temperature) for cooling only unit is -30°C ~ 43°C(-22°F ~ 109°F); for heat pump unit is -30°C ~ 43°C(-22°F ~ 109°F).

**GWHD(18)ND3MO**

1. Remove the handle at the right side plate of the outdoor unit (one screw).
2. Remove the cable clamp, connect the power connection cable with the terminal at the row of connection and fix the connection. The fitting line distributing must be consistent with the indoor unit terminal of line bank. Wiring should meet the one of indoor unit.
3. Fix power connection wire by wire clamp.
4. Ensure wire has been fixed well.
5. Install the handle.



An all-pole disconnection switch having a contact separation of at least 1/8" (3mm) in all poles should be connected in fixed wiring.



Wrong wire connection may cause malfunction of some electric components. After fixing cable, ensure that there is enough space between connection to fixed point.



The connection pipes and the connection wirings of the unit A, unit B must be corresponding to each other respective.



The appliance shall be installed in accordance with national wiring regulations.



Including an air switch with suitable capacity, please note the following table. Air switch should include a magnet buckle and heating buckle function, it can protect the circuit-short and overload. (Caution: please do not use the fuse only to protect the circuit)

Note: The above figures are only intended to be a simple diagram of the appliance and may not correspond to the appearance of the units that have been purchased.

Heat Pump	Circuit capacity
GWHD(18)ND3MO	20A

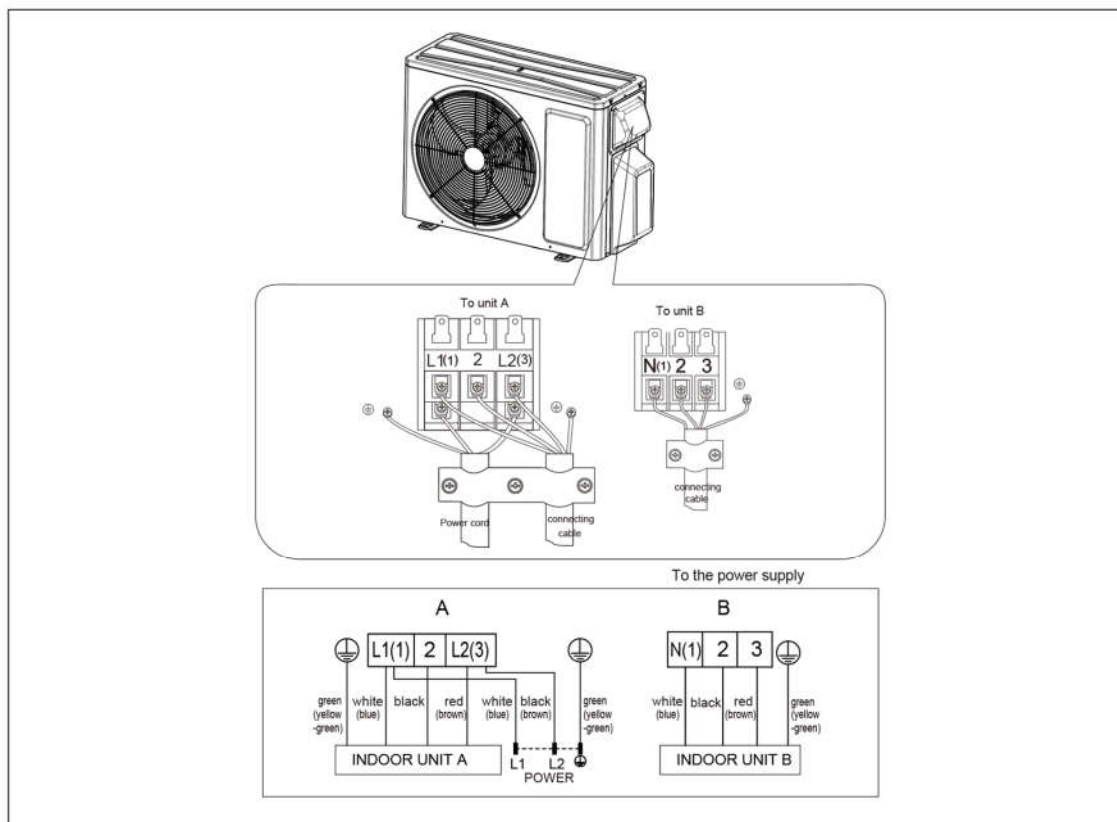

**HANDLING**

**USER**



After having removed the packaging, check that the contents are intact and complete.



Handling must be done by suitably equipped qualified technical personnel using equipment that is for suitable the weight of the appliance.



The outdoor unit must always be kept upright.

1. Remove the handle at the right side plate of the outdoor unit (one screw).
2. Remove the cable clamp, connect the power connection cable with the terminal at the row of connection and fix the connection. The fitting line distributing must be consistent with the indoor unit. terminal of line bank. Wiring should meet that of indoor unit.
3. Fix power connection wire by wire clamp.
4. Ensure wire has been fixed well.
5. Install the handle.

**⚠** Including an air switch with suitable capacity, please note the following table. Air switch should be included magnet buckle and heating buckle function, it can protect the circuit-short and overload. (Caution: please do not use the fuse only to protect the circuit)

Heat Pump	Circuit capacity
GWHD(24)ND3MO	25A



An all-pole disconnection switch having a contact separation of at least 1/8" (3mm) in all poles should be connected in fixed wiring.



Wrong wire connection may cause malfunction of some electric components. After fixing cable, ensure that there is enough space between connection to fixed point.



The connection pipes and the connection wirings of the unit A, unit B and unit C must be corresponding to each other respective.



The appliance shall be installed in accordance with national wiring regulations.

Note: The above figures are only intended to be a simple diagram of the appliance and may not correspond to the appearance of the units that have been purchased.

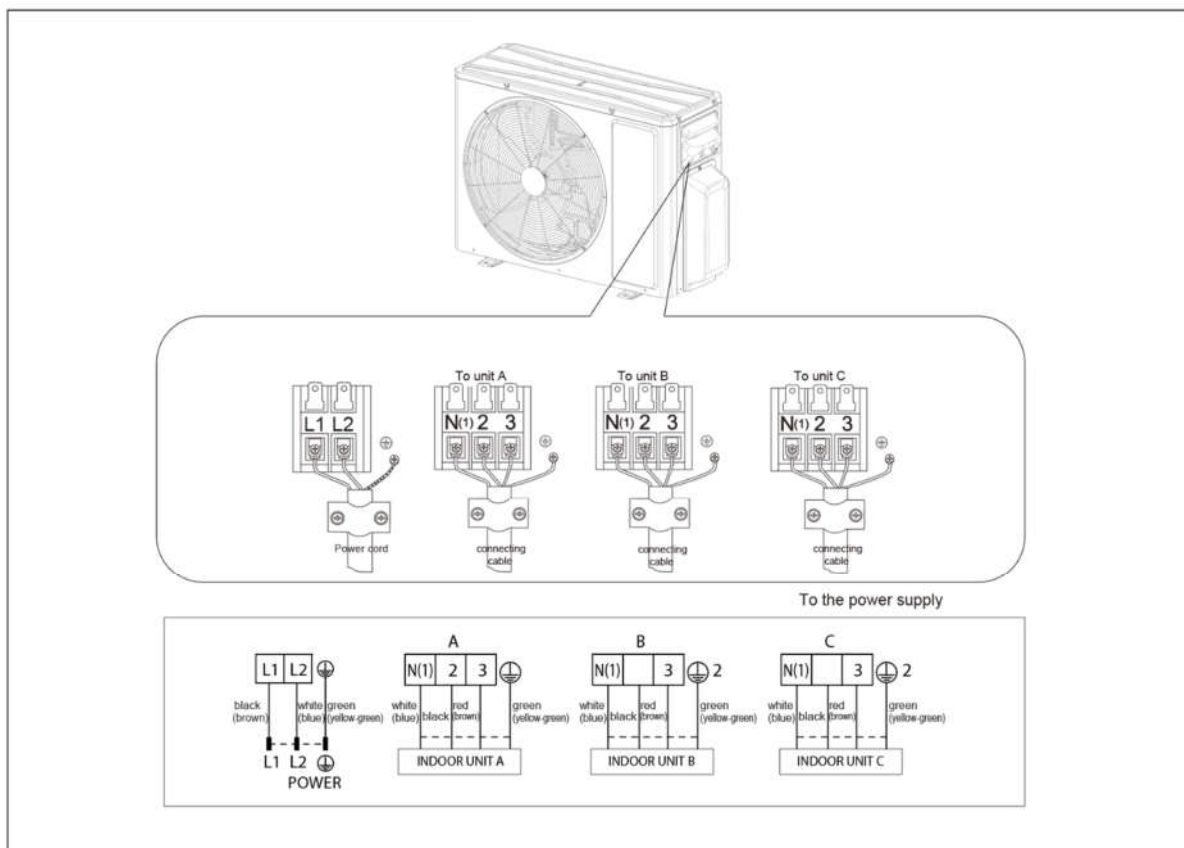

1. Remove the handle at the right side plate of the outdoor unit (one screw).
2. Remove the cable clamp, connect the power connection cable with the terminal at the row of connection and fix the connection. The fitting line distributing must be consistent with the indoor unit terminal of line bank. Wiring should meet that of indoor unit.
3. Fix power connection wire by wire clamp.
4. Ensure wire has been fixed well.
5. Install the handle.

**⚠** Including an air switch with suitable capacity, please note the following table. Air switch should be included magnet buckle and heating buckle function, it can protect the circuit-short and overload. (Caution: please do not use the fuse only to protect the circuit)

Heat Pump	Circuit capacity
GWHD(30)ND3MO	35A
GWHD(36)ND3MO	45A

- ⚠** An all-pole disconnection switch having a contact separation of at least 1/8" (3mm) in all pole should be connected in fixed wiring.
- ⚠** Wrong wire connection may cause malfunction of some electric components. After fixing cable, ensure that there is enough space between connection to fixed point.
- ⚠** The connection pipes and the connection wirings of the unit A, unit B, unit C and unit D must be corresponding to each other respective.
- ⚠** The appliance shall be installed in accordance with national wiring regulations.

Note: The above figures are only intended to be a simple diagram of the appliance and may not correspond to the appearance of the units that have been purchased.

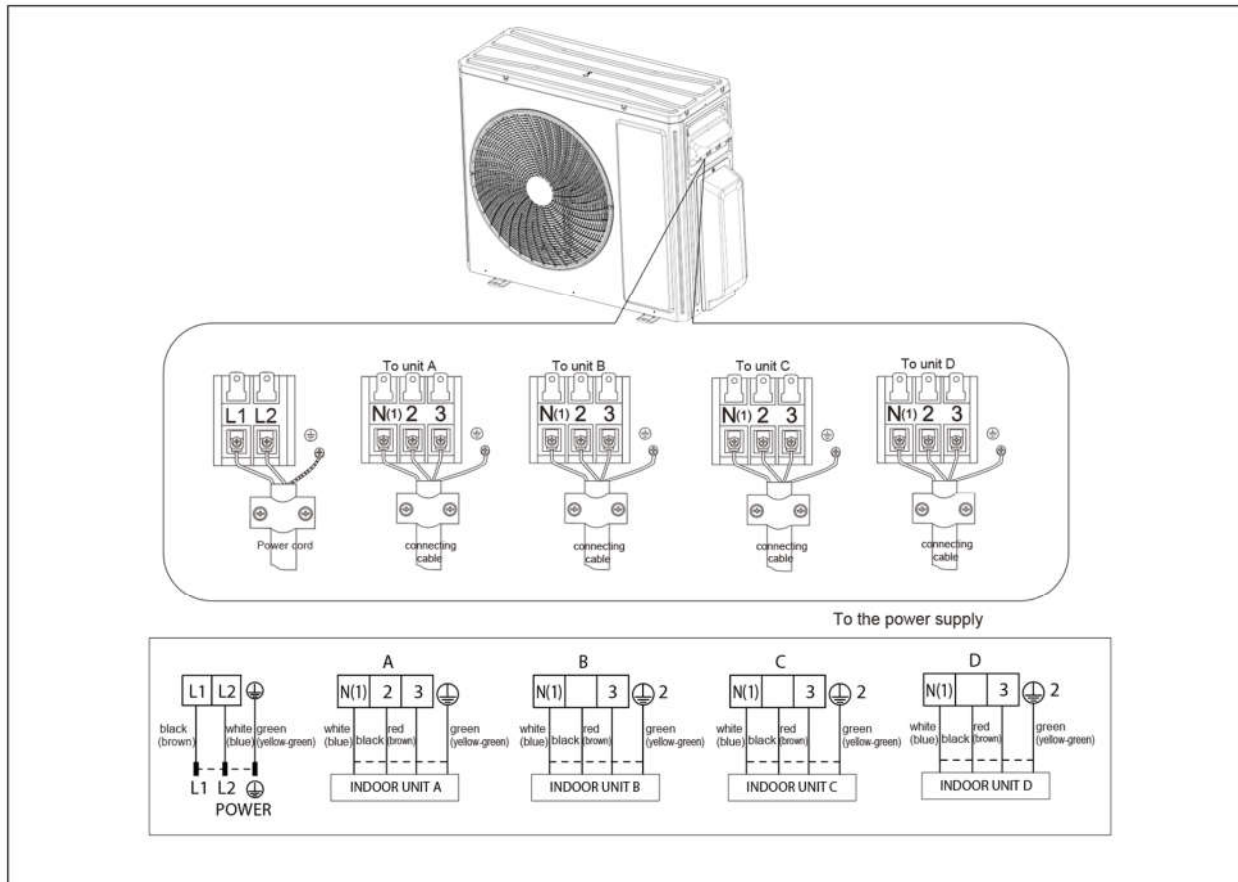

1. Remove the handle at the right side plate of the outdoor unit (one screw).
2. Remove the cable clamp, connect the power connection cable with the terminal at the row of connection and fix the connection. The fitting line distributing must be consistent with the indoor unit terminal of line bank. Wiring should meet that of indoor unit.
3. Fix power connection wire by wire clamp.
4. Ensure wire has been fixed well.
5. Install the handle.

**!** Including an air switch with suitable capacity, please note the following table. Air switch should be included magnet buckle and heating buckle function, it can protect the circuit-short and overload. (Caution: please do not use the fuse only to protect the circuit)

Heat Pump	Circuit capacity
GWHD(42)ND3MO	45A



An all-pole disconnection switch having a contact separation of at least 1/8" (3mm) in all pole should be connected in fixed wiring.



Wrong wire connection may cause malfunction of some electric components. After fixing cable, ensure that there is enough space between connection to fixed point.



The connection pipes and the connection wirings of the unit A, unit B, unit C, unit D and unit E must be corresponding to each other respective.



The appliance shall be installed in accordance with national wiring regulations.

Note: The above figures are only intended to be a simple diagram of the appliance and may not correspond to the appearance of the units that have been purchased.

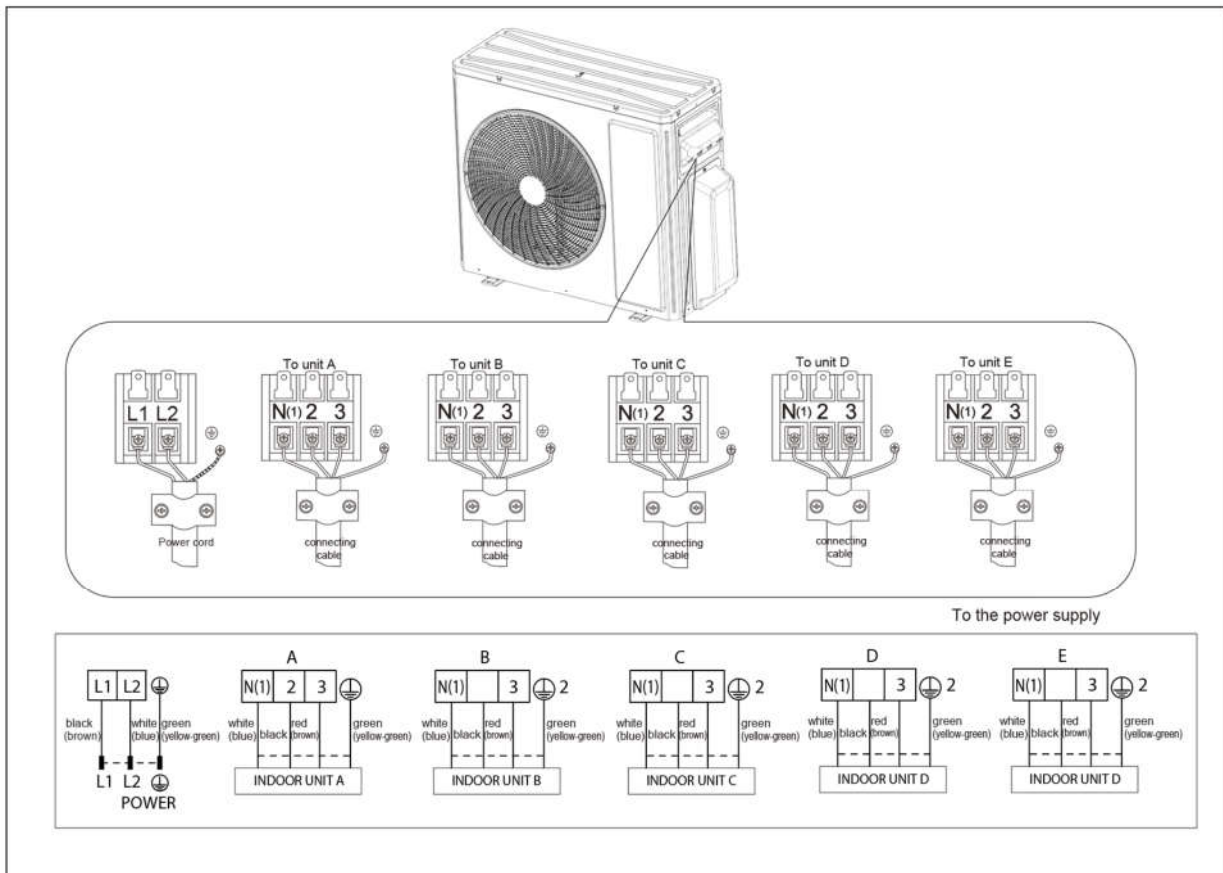

## INSTALLING THE OUTDOOR UNIT

INSTALLER

### Location

- ▲ Use bolts to secure the unit to a flat, solid floor. When mounting the unit on a wall or the roof, make sure the support is firmly secured so that it cannot move in the event of intense vibrations or a strong wind.

- Do not install the outdoor unit in pits or air vents

### Installing the pipes

- ▲ Use suitable connecting pipes and equipment for the refrigerant R410A.

Models(m)	18K	24K	30K	36K	42K
Max. connection pipe length	40	60	80	80	100
Max. connection pipe length (Simple one indoor unit)	20	20	25	25	25

- ▲ The refrigerant pipes must not exceed the maximum heights 15m(18K&24K), 25m(30K&36K&42K).
- ▲ Wrap all the refrigerant pipes and joints.
- ▲ Tighten the connections using two wrenches working in opposite directions.

**Caution: Installation Must be Performed in Accordance with the NEC/CEC by Authorized Personnel Only.**

### Install the drain fitting and the drain hose (for model with heat pump only)

Condensation is produced and flows from the outdoor unit when the appliance is operating in heating mode. In order not to disturb neighbours and to respect the environment, install a drain fitting and a drain hose to channel the condensate water. Install the drain fitting and rubber washer on the outdoor unit chassis and connect a drain hose to it as shown in the figure.

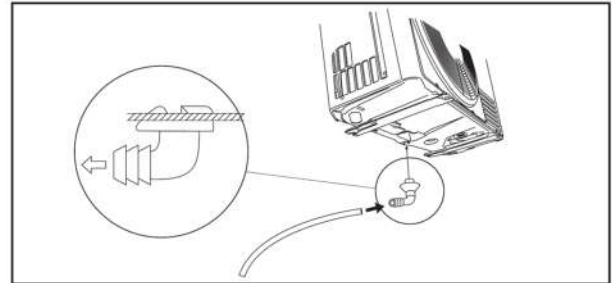

## BLEEDING

INSTALLER

Humid air left inside the refrigerant circuit can cause compressor malfunction. After having connected the indoor and outdoor units, bleed the air and humidity from the refrigerant circuit using a vacuum pump.

- (1) Unscrew and remove the caps from the 2-way and 3-way valves.
- (2) Unscrew and remove the cap from the service valve.
- (3) Connect the vacuum pump hose to the service valve.
- (4) Operate the vacuum pump for 10-15 minutes until an absolute vacuum of 10 mm Hg has been reached.
- (5) With the vacuum pump still in operation, close the low-pressure knob on the vacuum pump coupling. Stop the vacuum pump.
- (6) Open the 2-way valve by 1/4 turn and then close it after 10 seconds. Check all the joints for leaks using liquid soap or an electronic leak device.
- (7) Turn the body of the 2-way and 3-way valves. Disconnect the vacuum pump hose.
- (8) Replace and tighten all the caps on the valves.

Diamete	Twisting moment
1/4"	15-20
3/8"	35-40
5/8"	60-65
1/2"	45-50
3/4"	70-75

When the adaptor is required for the connection of indoor unit and the 24K, 30K, 36K, 42K outdoor unit, the method of pipe connection as follows:

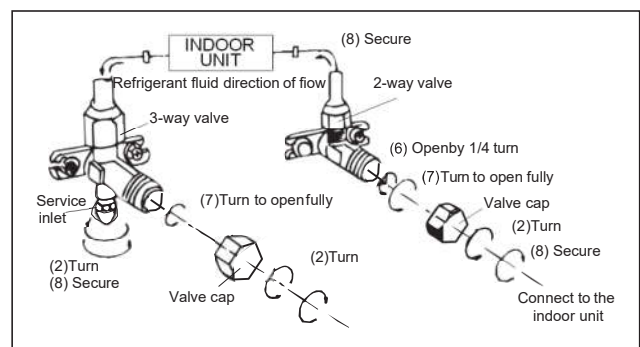
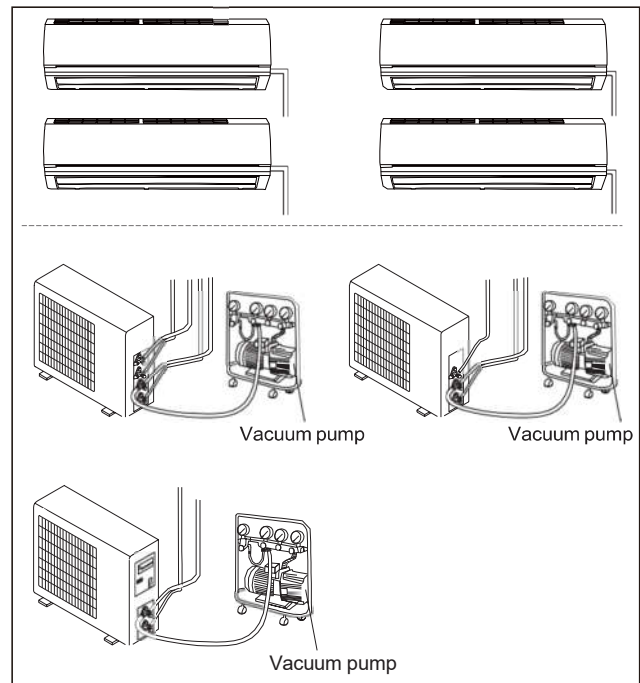
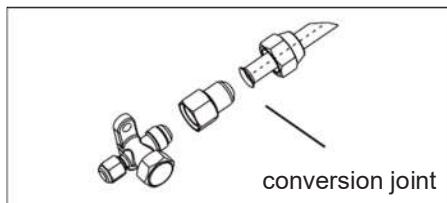

**MAINTENANCE****INSTALLER**

- ⚠ Use suitable instruments for the refrigerant R410A.
- ⚠ Do not use any other refrigerant than R410A.
- ⚠ Do not use mineral oils to clean the unit.

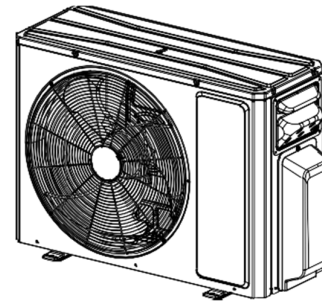
**INSTALLATION DIMENSION DIAGRAM****INSTALLER**

- ⚠ The installation must be done by trained and qualified service personnel with reliability according to this manual.
- ⚠ Contact service center before installation to avoid the malfunction due to unprofessional installation.
- ⚠ When picking up and moving the units, you must be guided by trained and qualified person.
- ⚠ Ensure that the recommended space is left around the appliance.

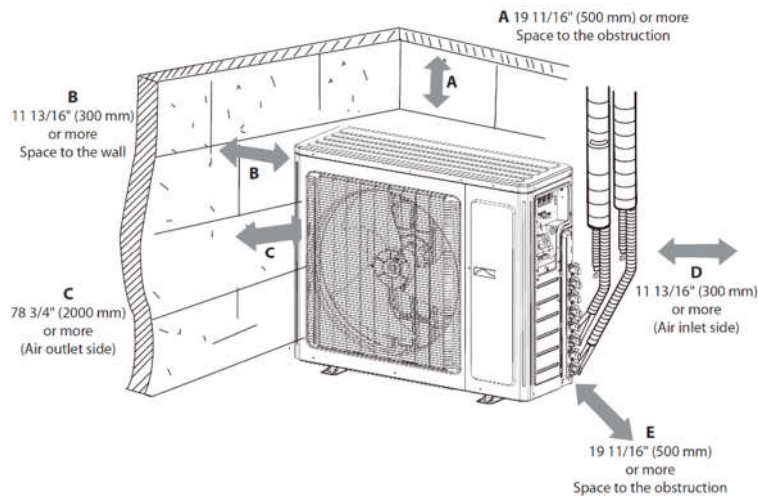
**Fix the support of outdoor unit (select it according to the actual installation situation)**

1. Select installation location according to the house structure.
2. Fix the support of outdoor unit on the selected location with expansion screws.

**NOTICE:**

- Take sufficient protective measures when installing the outdoor unit.
- Make sure the support can withstand at least four times of the unit weight.
- The outdoor unit should be installed at least 3cm above the floor in order to install drain joint. (for the model with heating tube, the installation height should be no less than 20cm.)
- For the unit with cooling capacity of 2300W ~ 5000W, 6 expansion screws are needed, for the unit with cooling capacity of 6000W~8000W, 8 expansion screws are needed; for the unit with cooling capacity of 10000W~16000W, 10 expansion screws are needed.
- As for the shape of drainage joint, please refer to the current product. Do not install the drainage joint in the severe cold area. Otherwise, it will be frosted and then cause malfunction.

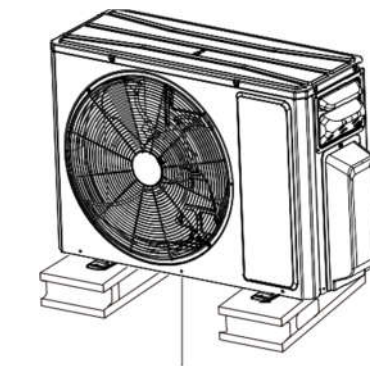

at least 3 cm above the floor

<b>Check Items</b>	<b>Problems Owing to Improper Installation</b>
Is the installation reliable?	The unit may drop, vibrate or make noises
Has the gas leakage been checked?	May cause inadequate cooling (heating) effect
Is the thermal insulation of the unit sufficient?	May cause condensation and water dropping
Is the drainage smooth?	May cause condensation and water dropping
Does the power supply voltage accord with the rated voltage specified on the nameplate?	The unit may bread down or the components may be burned out
Are the lines and pipelines correctly installed?	The unit may bread down or the components may be burned out
Has the unit been safely grounded?	Risk of electrical leakage
Are the models of lines in conformity with requirements?	The unit may bread down or the components may be burned out
Are there any obstacles near the air inlet and outlet of the indoor and out- door units?	The unit may bread down or the components may be burned out
Have the length of refrigerating pipe and refrigerant charge amount been recorded?	It is not easy to decide the charge amount of refrigerant.